

CLAPETI DE RETINERE CU FLANSE

Domeniu de aplicare

□aplicatii industriale (aburi, gaze naturale, apa rece, apa calda, fluide fara aciditate sau alcalinitate, GPL, aer comprimat).

Caracteristici constructive

□presiune de lucru 16 bar;
□temperatura de lucru max. +200° C.

Materiale

1.Corp	fonta turnata GG 25;
2.Capac	fonta turnata GG 25;
3.Flanse	fonta turnata GG 25;
4.Disc	otel inox SAE 304;
5.Arc	otel inox SAE 304;
6.Garnituri de etansare	cauciuc PTFE.



CLAPETI DE RETINERE CU FLANSE

Elemente componente

1.Corp
2.Capac
3.Flanse

4.Disc
5.Arc
6.Garnituri de etansare

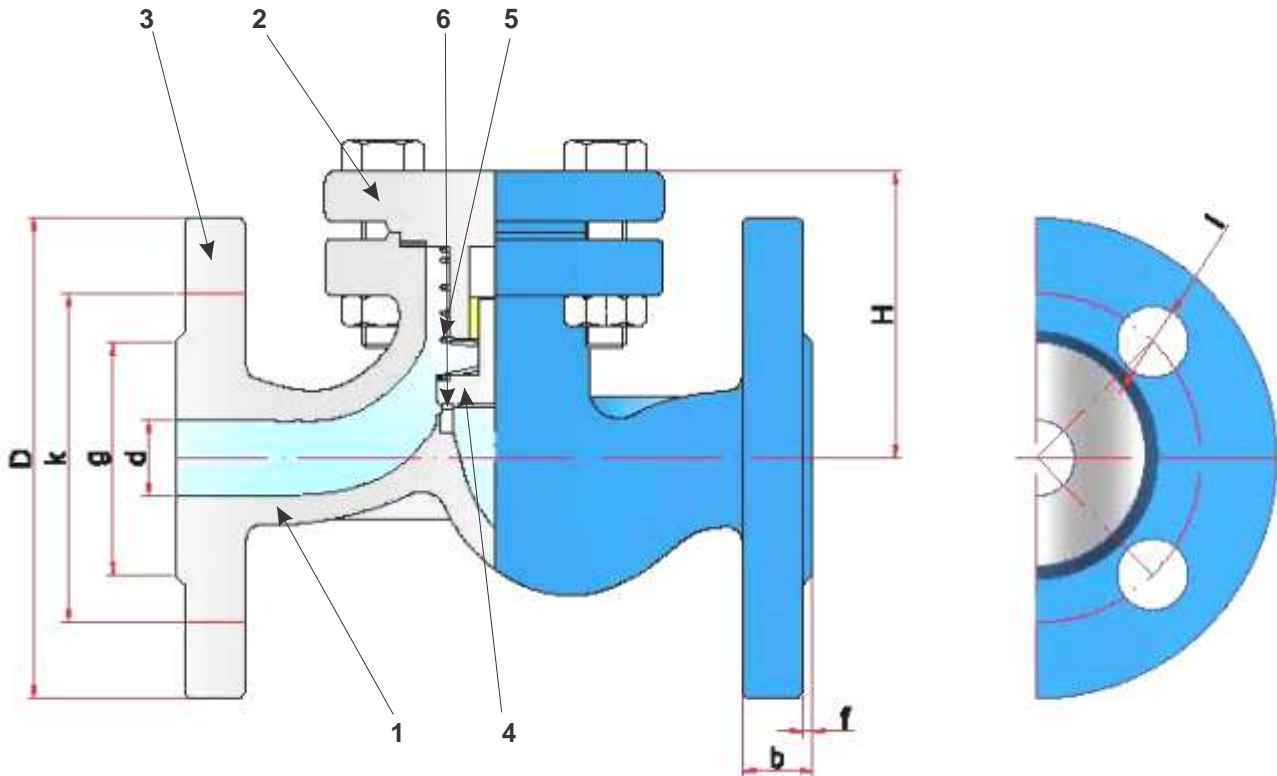

Caracteristici tehnice

DN	Dimensiuni		Flan e conform ISO 7005-2							Date produs		
Ømm	H	L	d	g	k	D	l	b	f	Numar gauri	KVS m ³ /h	Greutate Kg
15	60	130	15	46	65	95	14	14	2	4	3	2,40
20	65	150	20	56	75	105	14	16	2	4	5,5	3,26
25	70	160	25	65	85	115	14	16	3	4	8	4,58
32	85	180	32	76	100	140	19	18	3	4	13	7,01
40	90	200	40	84	110	150	19	18	3	4	20	8,98
50	100	230	50	99	125	165	19	20	3	4	33	11,97
65	120	290	65	118	145	185	19	20	3	4	50	16,61
80	140	310	80	132	160	200	19	22	3	8	88	22,98
100	160	350	100	156	180	220	19	24	3	8	119	31,17
125	180	400	125	184	210	250	19	26	3	8	187	43,81
150	200	480	150	211	240	285	23	26	3	8	266	66,21
200	250	600	200	266	295	340	23	30	3	12	478	121,12
250	300	730	250	319	355	405	28	32	3	12	740	201,10